

NO.	PART NO.	NAME	MATERIAL	COLOR	QTY
1		USB A/F DIP 90° 胶壳	PBT/LCP		1PCS
2		USB A/F DIP 90° 直脚9.4元自锁外壳(有圆边)	Copper Alloy/SPCC		1PCS
3		USB A/F 90° DIP长端子	Copper Alloy		4PCS

REVISIONS		
LET	DESCRIPTION	DATE
A	第一次制定	2016. 01. 20

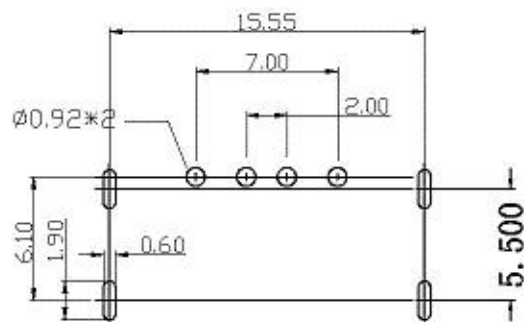
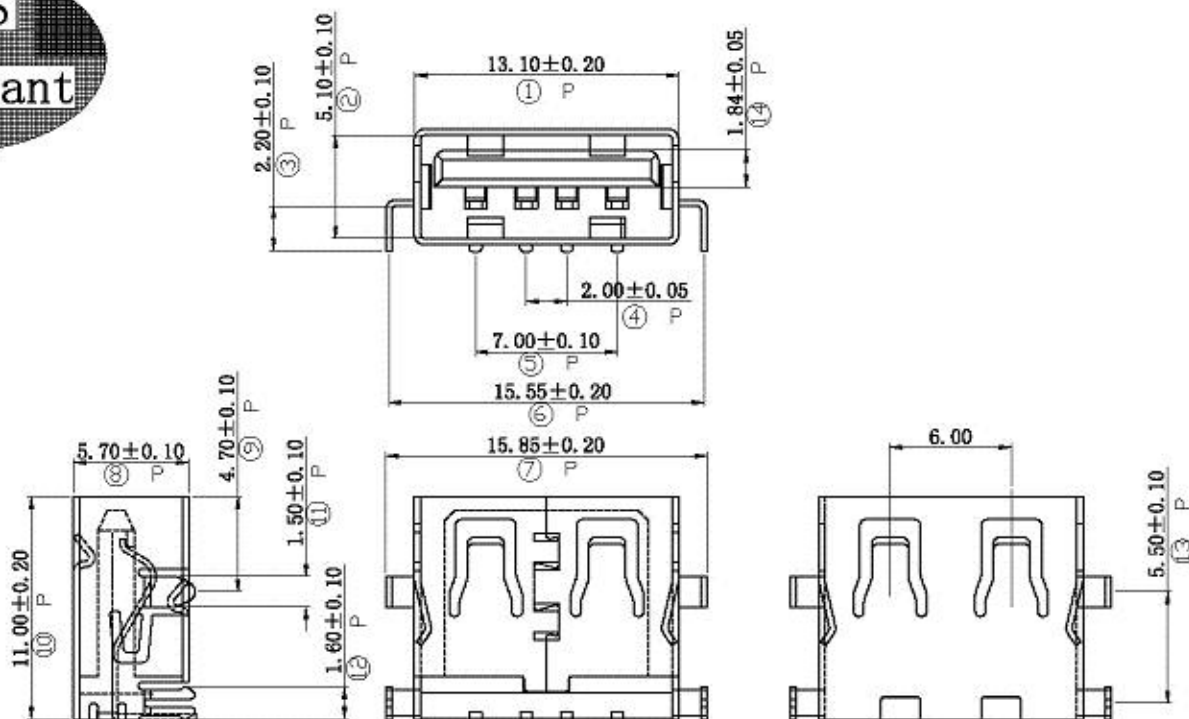

NOTES:

- MATERIAL SPECIFICATION
 - INSULATION MATERIAL THERMOPLASTIC.
 - SHELL: SPCC, T: 0.30mm
PLATING: NICKEL
 - TERMINAL: COPPER ALLOY, T: 0.25mm
PLATING: GOLD/TIN PLATED.
- ELECTRICAL CHARACTERISTIC:
 - INSULATION RESISTANCE: 1000MΩ MIN.
 - CONTACT RESISTANCE: 30mΩ MAX.
 - WITHSTANDING VOLTAGE: 500V AC.
- MECHANICAL CHARACTERISTICS:
 - INSERTION FORCE: 3.57Kgf MAX.
 - EXTRACTION FORCE: 1.02Kgf MIN.

ORDERING INFORMATION

 CTC Connection Technologies Corporation	DRAWING BY	Brand/Model:
	陈易容	USB90-SMT1.9
	CHECK BY	PART NAME:
	覃艺庆	成品图
APPROVED	DRAWING NO.	
	A02-D251L08N-0074	
DATE:	USER'S OR TOOLING NO.	
2016. 01. 20		

	TOLERANCE				
	X.	X.X	X.XX	X.XXX	X.*
A	± 0.20	± 0.10	± 0.05	± 0.03	± 1°
B	± 0.50	± 0.20	± 0.10	± 0.05	± 2°
✓ C	± 0.80	± 0.40	± 0.20	± 0.10	± 3°

MATERIAL:	UNIT:	 THIRD ANGLE
SUPERFICIES:	M/M	
COLOR:	SCALE: 1:1	
	REV: A	